

**WARNING: DEVIATION FROM THESE INSTALLATION INSTRUCTIONS MAY LEAD TO IMPROPER ENGINE OPERATION WHICH COULD CAUSE PERSONAL INJURY TO OPERATORS OR OTHER NEARBY PERSONNEL.**

## **1.0 DESCRIPTION**

- 1.1 The Altronic DISN 800 ignition system consists of these basic components:
1. DISN 800 Series Unit (7918xx-1xxC models)
  2. Hall-effect Pickup Sensor (791050 series)
  3. Magnet Disc
  4. Output Wiring Harness
  5. Cable Assembly, Pickup Sensor (793007 series)
  6. Cable Assembly, Timing Control (793020 series)
  7. Ignition Coils - one per spark plug; use only the following types: 501061, 591010, 501061-S, 591010-S, 591007, 591011A, 591011B, 591012, 591018.
- See drawing 709 811 for the general system layout.
- 1.2 The DISN 800 series unit has up to eight application programs which are selected by the application switch on the side of the unit - see drawing 799 044.
- 1.3 The DISN system is designed to operate from a nominal 12 Vdc or 24 Vdc battery or power supply. Refer to drawing 709 810 for details of the power hook-up. The DISN unit steps up the DC supply voltage to charge an energy storage capacitor and contains microcircuit logic and SCR switching devices to release the stored energy to the ignition coils in programmed, timed sequence according to the application. The only attachment to a rotating part of the engine is the timing magnet disc. The magnets signal the position of the engine crankshaft to the logic circuitry in the DISN unit. One additional magnet trails a few degrees after the last firing magnet; the DISN unit recognizes this as the index signal that another revolution is to begin.

## **2.0 DISN UNIT**

- 2.1 Refer to drawing 799 044 for DISN mounting dimensions. Install the DISN unit within 15 ft. (5 m.) of the furthest ignition coil and in a relatively cool location. The outside case temperature of the DISN unit should not exceed 150°F. (65°C.) in operation.
- 2.2 Mount the DISN unit securely with four (4) 1/4" diameter screws. Use shock mounts if mounting the unit directly to the engine. The metal case should be grounded to the engine; a grounding screw is provided on the case of the unit for this purpose.

### **3.0 MAGNET DISC / PICKUP SENSOR**

3.1 See drawings 709 812 and 791 050:

- A. On 4-cycle engines, the disc mounts to the camshaft or other shaft operating at one-half engine speed. On 2-cycle engines, the disc mounts to the engine crankshaft.
- B. Set the engine with no. 1 cylinder 2.0 crankshaft degrees, 4-cycle or 1.0 degree, 2-cycle ahead of the most advanced desired timing point on the compression stroke. This is the point where the Hall-effect pickup must line-up with the edge of the magnet next to the "x" on the O.D. of the disc (see drawing 709 812). When mounting the magnet disc, be sure to observe the rotation arrow marked on the disc.

NOTE: On certain engines, a cylinder other than no. 1 must be used when lining up the disc and pickup; refer to the applicable data chart (pages 7-9).

NOTE: On certain engines, a larger lead angle must be used when lining up the disc and pickup; refer to the applicable data chart (pages 7-9).

- C. Mount the Hall-effect pickup sensor (drawing 791 050) securely to a rigid bracket or surface to maintain an air gap not exceeding .040" (1,0 mm). The center of the pickup face must also line up with the center of the disc as it rotates - see drawing 709 812.

3.2 Plug the cable for the pickup into the 6-pin connector of the DISN unit; the 3-pin connector end plugs into the Hall-effect pickup.

### **4.0 IGNITION COILS**

4.1 Use only the Altronic coils indicated in section 1.1.

4.2 Mount the ignition coils as close to the spark plugs as possible keeping the high-tension lead length to a minimum but also keeping temperature below 200°F. (95°C.) during operation.

### **5.0 POWER WIRING**

5.1 The DISN system requires a battery or other DC power source with a voltage between 12 and 28 VDC. The minimum voltage at cranking speed for proper operation is 8 volts. Refer to drawing 709 810 for details of the connection to the DC power source.

NOTE: DEVICE IS POLARITY SENSITIVE. In the 6-pin pickup cable assembly, lead "E" must be connected to the positive (+) power lead and lead "F" to the negative (-) power lead.

## **6.0 PRIMARY WIRING**

- 6.1 The main wiring harness with the 10 or 19 pin connector plugs into the larger connector of the DISN unit. See the specific unit data chart (pages 7-9) for the firing order of the application being used. Starting with lead "A", the harness leads are connected in accordance with the engine's firing order to the positive (+) terminals of the coils - see wiring diagram 709 813 and the applicable unit data chart.
- 6.2 A common ground lead connecting the negative (–) terminals of the coils must be run as shown in the wiring diagrams and be connected to the "J" harness lead. In addition, for the coils at the end cylinders of each bank (4 total on V-type engine) it is necessary to run a short wire from the negative (–) terminal of the coil to engine ground. For minimum emitted RFI, ground each coil's negative (–) terminal in this manner.
- 6.3 All connections should be made using ring type terminals specified for no. 16 gauge (1.5 sq. mm) wire and #10 stud size. Terminals should either be soldered to the wire or attached with an appropriate staking tool. All primary wiring should be protected from physical damage, vibration and temperatures in excess of 200°F. (95°C.).
- 6.4 If two ignition coils per cylinder are used, use parallel wiring as shown on wiring diagram 709 813.
- 6.5 SHIELDED SYSTEM - For component layout and wiring for a shielded system, see drawing 709 814.

## **7.0 SHUTDOWN WIRING**

- 7.1 The DISN system can be shut-off in two ways:
  - A. OPTION 1 - Interrupt the DC power to the unit; use a switch or relay with contacts rated 24 VDC, 10 amps - refer to wiring diagram 709 813.
  - B. OPTION 2 - Ground the "G" harness lead; this may be used if the panel (1) was powered from an Altronic I, III or V ignition system and (2) utilizes Altronic instruments if electronic instrumentation is used. Refer to wiring diagram 709 813. When the "G" lead is grounded, the DISN unit will draw about 0.1 amp from the power source.

NOTE: If desired, the "G" lead may be used to power Altronic display instruments in the panel and OPTION 1 used to shut-off the ignition.

## **8.0 TIMING CONTROL WIRING**

- 8.1 The timing control cable assembly (if used) plugs into the 5-pin control connector on the side of the unit next to the two switches. Refer to section 11.4 and drawing 709 815 for the specific wiring hook-up.

## **9.0 ALARM OUTPUT WIRING**

- 9.1 The alarm output consists of a normally-closed, solid-state switch at lead "D" of the 6-pin pickup cable assembly. Upon detection of a pickup or primary output fault, this switch will open circuit. Pickup faults are non-latching and will follow the actual condition. Primary output faults will latch the alarm output in the faulted (open) position until the speed comes to zero and the next startup is attempted. Refer to wiring diagram 709 813 for the wiring hook-up. NOTE: On applications with unused "live" output leads, the alarm function cannot be used as it will always be in the faulted condition; see pages 7-9 for application specifics.

**CAUTION:** In order to prevent the ignition from stopping and restarting while the engine is still rotating in the event of a momentary pickup fault, the alarm output must be connected to a latching relay function to turn-off the ignition and stop the engine.

**CAUTION:** When replacing a DISN 400 unit, note the difference in the use of lead "D" of the 6-pin pickup cable assembly. If the dual timing function is required, use the analog timing capability - see section 11.4C. and drawing 709 815.

## **10.0 SECONDARY WIRING**

- 10.1 The spark plug leads should be fabricated from silicone insulated 7 mm cable with suitable terminals and silicone spark plug boots. The use of leads with resistor spark plug boots (Altronic series 59320x-xx) is recommended to minimize interference from emitted RFI on the operation of other nearby electronic equipment. Another option is the use of suppression ignition cable (Altronic part no. 503285). It is also essential to keep spark plug leads as short as possible and in all cases not longer than 24 inches (600 mm). Spark plug leads should be kept at least 2 inches (50 mm) away from any grounded engine part. In deep spark plug wells, use rigid, insulated extenders projecting out of the well.
- 10.2 The use of a clear, silicone grease (such as Dow Corning DC-4, G.E. G-623 or GC Electronics Z5) is recommended for all high-tension connections and boots. This material helps seal out moisture and prevent corrosion from atmospheric sources.

## **11.0 OPERATION**

- 11.1 BASIC OPERATION - The DISN unit steps up the DC supply voltage to charge an energy storage capacitor. SCR switching devices release this stored energy in response to signals from the unit's logic circuitry which processes signals from the rotating magnet disc. Even-firing applications have one magnet for every firing of the engine. Each firing occurs a programmed number of degrees after the magnet signal is received; this delay in degrees is adjustable - see sections 11.3 and 11.4. In odd-firing applications, two outputs are triggered from each magnet with the odd firing angle electronically determined by the DISN unit. One additional index magnet trails a few degrees after the last firing magnet in the sequence to indicate that another revolution is to begin.

- 11.2 APPLICATION SWITCH - The DISN 800 unit ("C" series) has an 8-position application switch located next to the manual timing switch at one end of the box. If the magnet disc pattern does not correspond to the application switch setting, the DISN unit will have no output and the APPLICATION indicator will light (see section 12.0). This is the diagnostic and safety interlock to prevent out-of-time sparks from occurring if the application switch and magnet disc pattern do not correlate.
- A. Set the application switch to the appropriate setting based on the engine - refer to the DISN Application List (form DISN AL) and the applicable data chart in these instructions (pages 7-9).
  - B. Replace the white cap over the application switch once the appropriate setting has been selected.

- 11.3 MANUAL TIMING SWITCH - The DISN unit has a 16-position timing switch located at one end of the box.

NOTE: The manual timing switch is active only if no voltage is applied to pin "E" of the 5-pin control connector.

- A. The timing range is 15 degrees on 4-cycle engines or 7.5 degrees on 2-cycle engines. Switch position 15 gives the most advanced timing. The timing retards approximately 1.0 degree, 4-cycle or 0.5 degree, 2-cycle for each switch position as the switch is moved to position 14, 13, 12, . . . 2, 1, 0. Switch position 0 is full retard.

**CAUTION: DO NOT switch from position 15 to 0, or 0 to 15 while the engine is running. The large timing change may cause the engine to shutdown or be damaged.**

- B. Replace the white cap over the timing switch once the desired timing setting has been selected.
- C. Connecting together leads "C" and "E" of the 5-pin control connector gives the timing determined by the analog timing input (see section 11.4). Opening the above connection reverts the unit to the timing set by the manual switch - see drawing 709 815. This feature gives the ability to switch between two timing settings for differences in fuel, load, temperature, etc. The differential range is 1-15 degrees, 4-cycle or 0.5-7.5 degrees, 2-cycle.

- 11.4 ANALOG TIMING ADJUSTMENT - Connecting together leads "C" and "E" of the 5-pin control connector enables the analog timing capability of the DISN 800 unit and disables the manual timing switch. The basic analog timing input may be connected to a 0-1,000 ohm potentiometer or to a 4-20 mA current loop control. The analog timing range is 16 degrees, 4-cycle or 8 degrees, 2-cycle. Refer to drawing 709 815 for the wiring hook-up.

## 12.0 TROUBLESHOOTING

12.1 NORMAL OPERATION - Check the three LED indicators located on the main label of the unit. The green POWER indicator is ON when power is applied. The red PICKUP and APPLICATION indicators are ON when there is a fault.

INDICATOR	POWER APPLIED ENGINE STOPPED	POWER APPLIED ENGINE ROTATING
POWER	ON	ON
PICKUP	ON*	OFF
APPLICATION	OFF	OFF**

\* No pickup signal generated due to lack of rotation.

\*\* This indicator will flash ON briefly when rotation commences and then turn OFF.

12.2 TROUBLESHOOTING - Check the three indicators located on the main label of the unit. If the engine will not start or run correctly, crank engine with fuel turned off and check per the chart below:

INDICATION AND CHECKS	REMEDY
<p><b>POWER Indicator OFF:</b></p> <ol style="list-style-type: none"> <li>1. Check voltage to leads E(+) and F(-) of 6-pin pickup cable.</li> <li>2. If above check is OK:</li> </ol>	<ol style="list-style-type: none"> <li>1. Must be in the range of 10-32 Vdc.</li> <li>2. Replace DISN unit.</li> </ol>
<p><b>PICKUP Indicator is ON with Engine Rotating:</b></p> <ol style="list-style-type: none"> <li>1. Check gap between pickup and magnets: .040"±.010" (1.0±0.25 mm)</li> <li>2. Check cable between pickup and DISN unit.</li> <li>3. Pickup may be defective.</li> <li>4. If above checks are OK:</li> </ol>	<ol style="list-style-type: none"> <li>1. Correct gap.</li> <li>2. Connect or replace cable.</li> <li>3. Replace pickup.</li> <li>4. Replace DISN unit.</li> </ol>
<p><b>APPLICATION Indicator is ON with Engine Rotating:</b></p> <ol style="list-style-type: none"> <li>1. Check that application switch setting matches engine application.</li> <li>2. Check that magnet pattern matches engine application.</li> <li>3. If above checks are OK:</li> </ol>	<ol style="list-style-type: none"> <li>1. Correct setting.</li> <li>2. Correct magnet disc or pattern.</li> <li>3. Replace DISN unit.</li> </ol>

### **13.0 DISN UNIT SPECIFICATIONS**

#### **DISN UNIT NO. 791808-100C**

APPLICATION SWITCH	NO. OF OUTPUTS	MAGNET DISC	FIRING DISC DEGS.	UNIT FIRING ORDER
A	4	4+1	90° even	A-B-C-D
B	5	5+1	72° even	A-B-C-D-E
C	6	6+1	60° even	A-B-C-D-E-F
D	8	8+1	45° even	A-B-C-D-E-F-H-I

#### **DISN UNIT NO. 791812-100C**

APPLICATION SWITCH	NO. OF OUTPUTS	MAGNET DISC	FIRING DISC DEGS.	UNIT FIRING ORDER
A	12	12+1	30° even	A-B-C-D-E-F-K-L-M-N-P-R
B	12	6+1	15°-45°	A-B-C-D-E-F-K-L-M-N-P-R
C	12	12+1	27.5°-32.5°	A-B-C-D-E-F-K-L-M-N-P-R
D	12	6+1	20°-40°	A-B-C-D-E-F-K-L-M-N-P-R
E	10	5+1	27°-45°	A-B-C-D-E-F-K-L-M-N
F	12	6+1	28°-32°	A-B-C-D-E-F-K-L-M-N-P-R

**DISN UNIT NO. 791816-100C**

APPLICATION SWITCH	NO. OF OUTPUTS	MAGNET DISC	FIRING DISC DEGS.	UNIT FIRING ORDER
A	6	6+1	60° even	A-B-C-D-E-F
B	4* 8* 16	8+1	90° even 45° even 22.5° even	A-E-M-S A-C-E-K-M-P-S-U A-B-C-D-E-F-K-L-M-N-P-R-S-T-U-V
C	12	12+1	30° even	A-B-C-D-E-F-K-L-M-N-P-R
D	16	8+1	15°-30°	A-B-C-D-E-F-K-L-M-N-P-R-S-T-U-V
E	5* 10	10+1	72° even 36° even	A-C-E-K-M A-B-C-D-E-F-K-L-M-N
F**	12	12+1	27.5°-32.5°	A-B-C-D-E-F-K-L-M-N-P-R
G	12	6+1	24°-36°	A-B-C-D-E-F-K-L-M-N-P-R
H	16	8+1	21°-24°	A-B-C-D-E-F-K-L-M-N-P-R-S-T-U-V

**DISN UNIT NO. 791816-101C**

APPLICATION SWITCH	NO. OF OUTPUTS	MAGNET DISC	FIRING DISC DEGS.	UNIT FIRING ORDER
A	6	6+1	60° even	A-B-C-D-E-F
B	4* 8* 16	8+1	90° even 45° even 22.5° even	A-E-M-S A-C-E-K-M-P-S-U A-B-C-D-E-F-K-L-M-N-P-R-S-T-U-V
C	12	12+1	30° even	A-B-C-D-E-F-K-L-M-N-P-R
D	16	8+1	15°-30°	A-B-C-D-E-F-K-L-M-N-P-R-S-T-U-V
E	12	12+1	37.5°-22.5°	A-B-C-D-E-F-K-L-M-N-P-R
F	12	6+1	15°-45°	A-B-C-D-E-F-K-L-M-N-P-R
G***	12	12+1	25°-35°	A-B-C-D-E-F-K-L-M-N-P-R
H	16	8+1	10°-35°	A-B-C-D-E-F-K-L-M-N-P-R-S-T-U-V

- \* With this application, the alarm output (section 9.0) cannot be used as it will always be faulted.
- \*\* Time magnet marked "x" 7.0 degrees ahead of most advanced desired timing for no. 1 cylinder.
- \*\*\* Time magnet marked "x" 12.0 degrees ahead of most advanced desired timing for no. 1 cylinder.

NOTE: See next page for special wiring instructions.



## APPLICATIONS WITH SPECIAL WIRING HOOK-UP

Listed below are applications for models 791816-100C and 791816-101C that time to a cylinder other than no. 1 or have a wiring sequence different from that shown above. Time the magnet disc to the cylinder indicated and leave all leads not assigned open-circuited (not connected).

NOTE: x = not used. With these applications, the alarm output (section 9.0) cannot be used as it will always be in the faulted condition.

ENGINE MODEL	APPLIC. SWITCH	TIME TO CYL.#																
			A	B	C	D	E	F	K	L	M	N	P	R	S	T	U	V
Caterpillar 3516	D	2	2	5	6	3	4	9	10	15	16	11	12	13	14	7	8	1
Caterpillar G379	C	1	1	8	x	5	4	x	7	2	x	3	6	x	x	x	x	x
Caterpillar G399	D	2	2	11	12	3	4	9	10	15	16	5	6	13	14	7	8	1
Clark MA-8, HMA-8	B	1	1	6	x	x	4	7	x	x	2	5	x	x	3	8	x	x
I-R 4JVG, 4XVG, PVG-4	C	1	1	x	x	2	x	x	x	3	x	x	4	x	x	x	x	x
I-R 6JVG, 6SVG	C	1	1	x	x	6	2	x	x	4	3	x	x	5	x	x	x	x
I-R 6XVG, PVG-6	C	1	1	x	x	2	4	x	3	5	x	x	6	x	x	x	x	x
I-R 8JVG, 8SVG	D	8	8	x	5	x	7	x	6	x	x	1	x	3	x	2	x	4
I-R 8XVG, PVG-8	C	1	1	8	x	3	6	x	4	5	x	2	7	x	x	x	x	x
I-R 48KVG, 83KVG	B	1	1	x	3	x	2	x	4	x	x	5	x	7	x	6	x	8
I-R 82KVG	B	1	1	8	x	x	3	6	x	x	4	5	x	x	2	7	x	x
MWM G232V6	C	A1	A1	x	x	B2	A3	x	x	B1	A2	x	x	B3	x	x	x	x
MWM G232V8	C	A1	A1	x	B2	A3	x	B1	A4	x	B3	A2	x	B4	x	x	x	x
Superior 16G825	H*	1L	1L	3R	3L	7R	7L	4R	4L	8R	8L	6R	6L	2R	2L	5R	5L	1R
Superior 16GT825	H*	1L	1L	3R	3L	2R	2L	5R	5L	8R	8L	6R	6L	7R	7L	4R	4L	1R
Waukesha H2475G	C	1R	1R	4L	x	3R	2L	x	4R	1L	x	2R	3L	x	x	x	x	x
Waukesha H2476G	C	1R	1R	4L	x	3R	2L	x	4R	1L	x	2R	3L	x	x	x	x	x
Waukesha P9390G -new	D	1L	1L	3R	3L	7R	7L	5R	5L	8R	8L	6R	6L	2R	2L	4R	4L	1R
Waukesha P9390G -old	D	8L	8L	6R	3L	2R	7L	5R	4L	8R	1L	3R	6L	7R	2L	4R	5L	1R

\* Applies to unit 791816-100C only.

## **DRAWINGS SECTION:**

709 810	DC POWER HOOK-UP
709 811	DISN 800 SYSTEM DIAGRAM
709 812	PICKUP / DISC INSTALLATION
709 813	WIRING DIAGRAM
709 814	DISN SHIELDED SYSTEM
709 815	TIMING CONTROL WIRING
791 050	HALL-EFFECT PICKUP
799 044	DISN UNIT - 800 SERIES

# D.C. POWER SOURCE

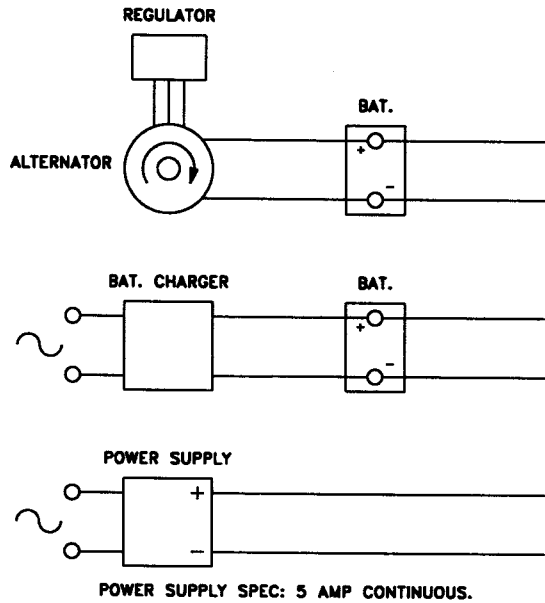

WIRE SIZE: 14 GA. (2,5 SQ. mm) MINIMUM

SWITCH RATING: 10 AMP MIN.

FUSE RATING: 10 AMP

### OPERATING VOLTAGE REQUIREMENT

CONDITION	MIN.	MAX.
STARTING	8 VDC	28 VDC
RUNNING	12 VDC	28 VDC

### AVERAGE CURRENT DRAW

DISN UNIT	GENERAL FORMULA	EXAMPLE: V12 ENGINE, 1800 RPM
12 VDC INPUT	$\frac{N \times \text{DISC RPM}}{5,000}$	$\frac{12 \times 900}{5,000} = 2.16 \text{ AMPS}$
24 VDC INPUT	$\frac{N \times \text{DISC RPM}}{10,000}$	$\frac{12 \times 900}{10,000} = 1.08 \text{ AMPS}$

N = NUMBER OF CYLINDERS

DISN UNIT  
800 SERIES

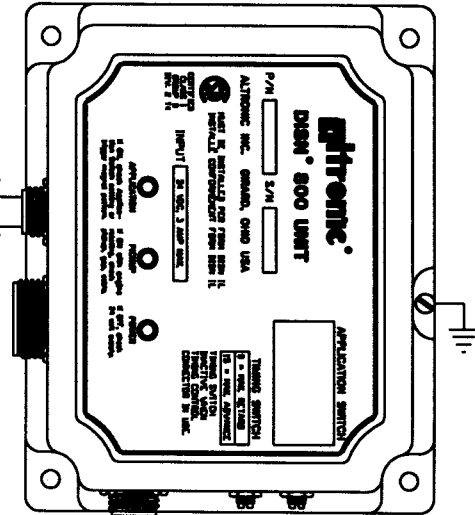

### NOTE:

INFORMATION IS PER ONE (1) DISN SYSTEM.  
FOR MULTIPLE SYSTEMS, MULTIPLY REQUIREMENTS  
BY NUMBER OF SYSTEMS.

REVISIONS				TOLERANCES (EXCEPT AS NOTED)		ALTRONIC INC.		
NO.	DATE	BY	DESCRIPTION	DECIMAL	TITLE	DRAWN BY		PART NUMBER
1				.XXX - ±.005	DC POWER HOOKUP DISN IGNITION SYSTEM	WTP		709 810
2				.XX - ±.010		CHECKED BY	DATE	
3				FRACTIONAL	APPROVED BY	SCALE	NONE	
4				MATERIAL			12-6-95	
5								

709 810

DISN 800 - SINGLE PICKUP SYSTEM  
(V12 ENGINE SHOWN)

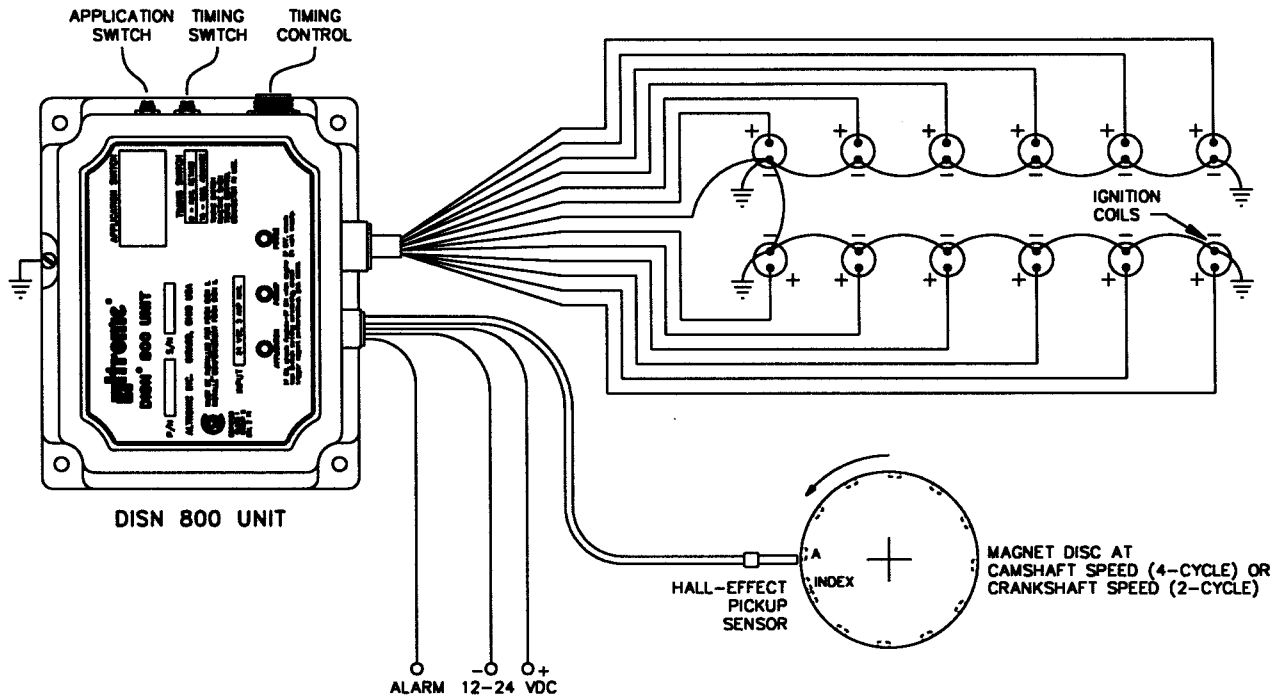

REVISIONS				TOLERANCES (EXCEPT AS NOTED)	ALTRONIC INC.				
NO.	DATE	BY	DESCRIPTION	DECIMAL .XXX - ±.005 .XX - ±.010	TITLE DISN 800 SYSTEM DIAGRAM SINGLE PICKUP SYSTEM				
1				FRACTIONAL	DRAWN BY	WTP	SCALE	NONE	PART NUMBER
2				MATERIAL	CHECKED BY		DATE	12-6-95	709 811
3					APPROVED BY				
4									
5									

709 811

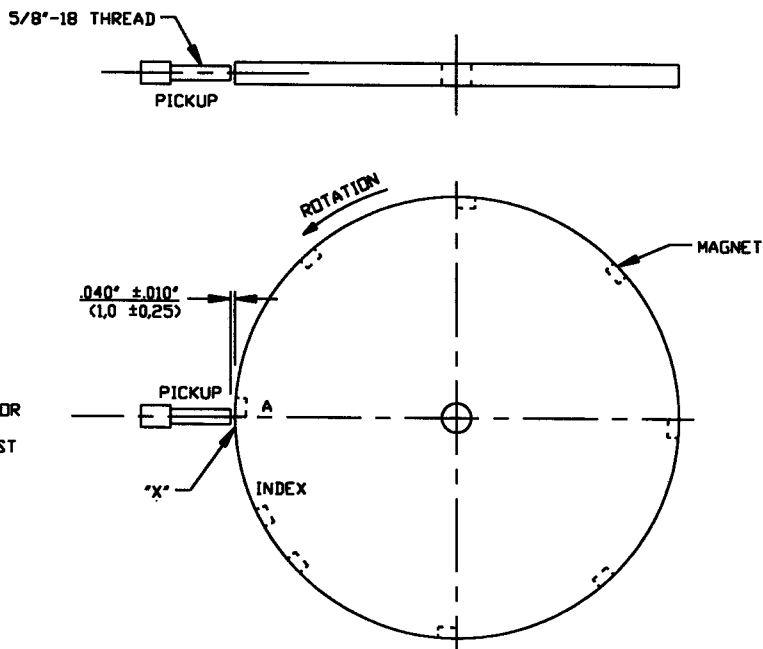

2°, 4-CYCLE OR  
1°, 2-CYCLE  
PRIOR TO MOST  
ADVANCED  
TIMING POINT

EXAMPLE: (4-CYCLE ENGINE)

MOST ADVANCED TIMING SETTING = 24° BTDC  
ENGINE SETTING FOR ABOVE LINE-UP = 26° BTDC  
ADJUSTABLE TIMING RANGE = 9°-24° BTDC

NOTE: (8 + 1) MAGNET DISC SHOWN.

REVISIONS				TOLERANCES (EXCEPT AS NOTED)	ALTRONIC INC.		
NO.	DATE	BY	DESCRIPTION	DECIMAL .XXX - ±.005 .XX - ±.010	TITLE PICKUP/DISC INSTALLATION SINGLE PICKUP SYSTEM		PART NUMBER 709 812
1				FRACTIONAL	DRAWN BY	VTP	
2				MATERIAL	CHECKED BY		DATE 12-8-95
3					APPROVED BY		
4							
5							

709 812

UNIT	WIRING																
791 816-100C	A/	B/	C/	D/	E/	F/	K/	L/	M/	N/	P/	R/	S/	T/	U/	V/	J/GND

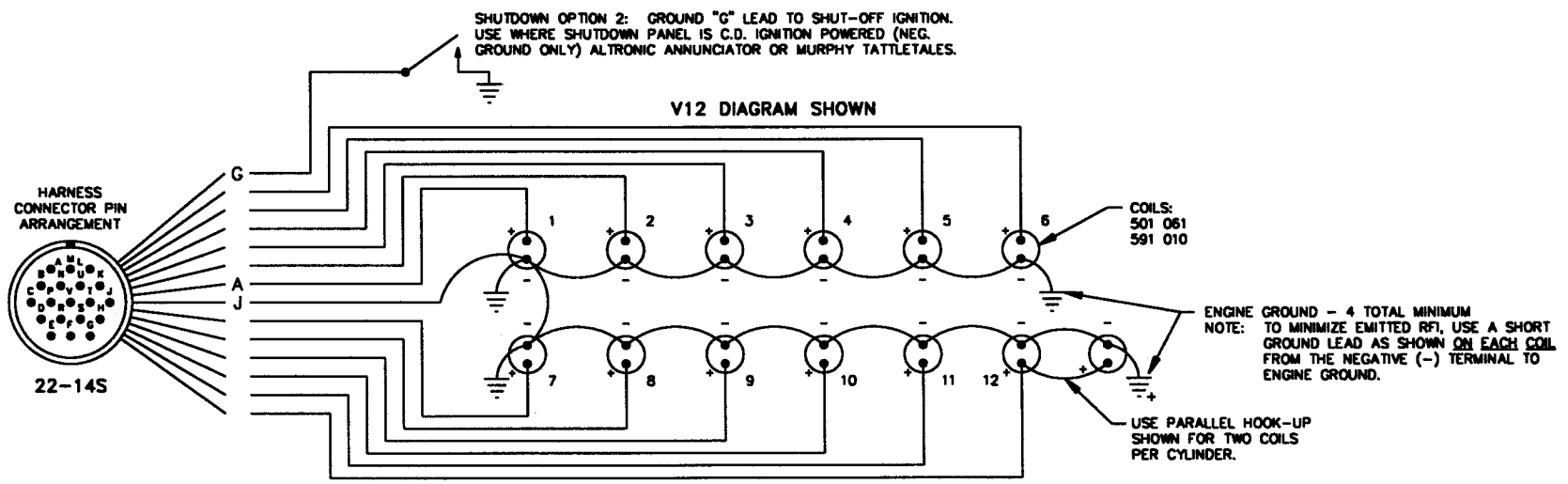
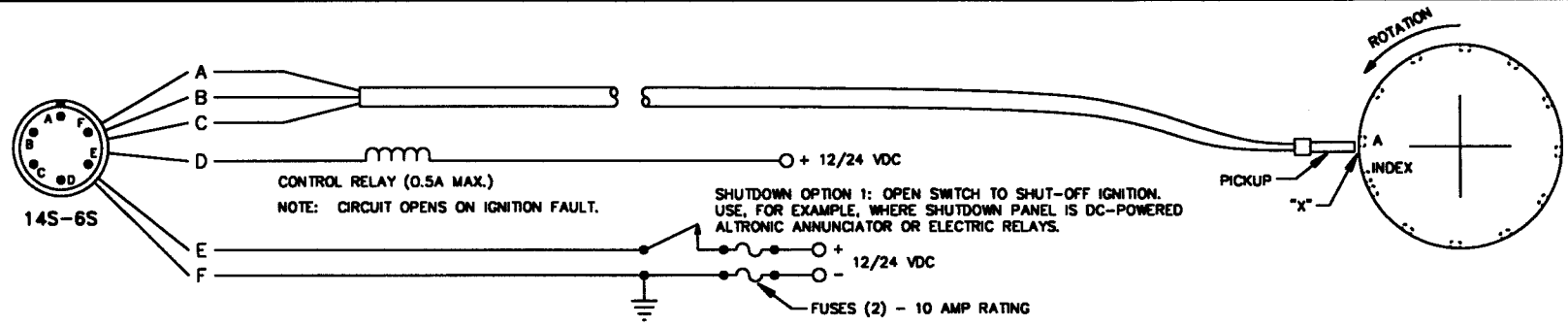

REVISIONS			
NO.	DATE	BY	DESCRIPTION
1			
2			
3			
4			
5			

TOLERANCES (EXCEPT AS NOTED)		ALTRONIC INC.	
DECIMAL .XXX - ±.005 .XX - ±.010	FRACTIONAL	TITLE WIRING DIAGRAM DISN SINGLE PICKUP SYSTEM	
MATERIAL	APPROVED BY	DRAWN BY WTP	PART NUMBER 709 813
		CHECKED BY	SCALE .888
		DATE 12-15-95	

709 813

SHIELDED PRIMARY CABLE 593 022 OR 593 027

DESIGNATES LEAD WIRE AND CONNECTOR ENTRY NO.

EXAMPLE: F2 IS LEAD "F" FROM ENTRY NO.2

**COLOR CODE**

A4 - A2 RED  
 B4 - B2 WHITE  
 C4 - C2 BLACK

SHIELDED CABLE

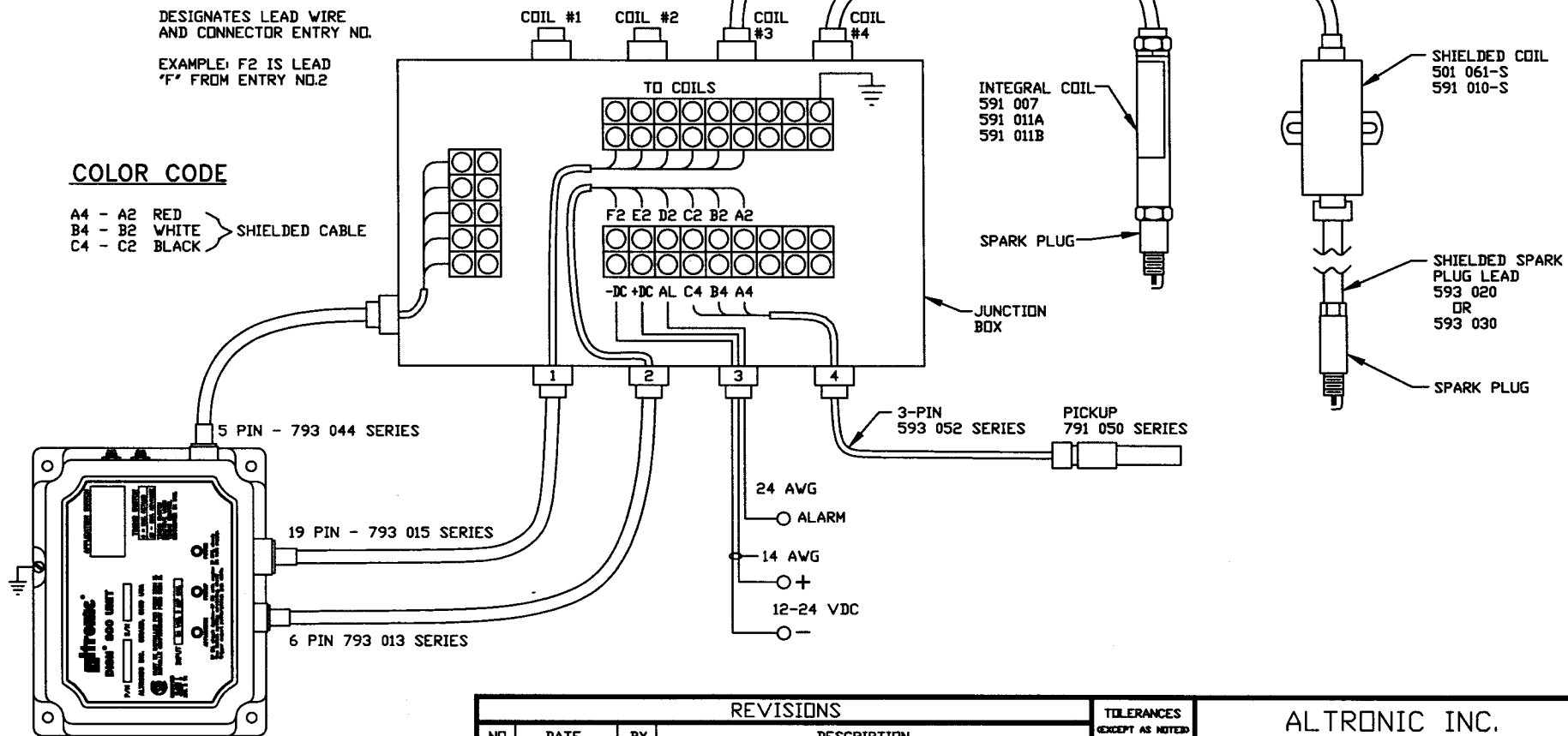

DISN 800 UNIT

REVISIONS				TOLERANCES (EXCEPT AS NOTED)		ALTRONIC INC.			
NO.	DATE	BY	DESCRIPTION	DECIMAL		TITLE			
1				.XXX	±.005	DISN SHIELDED SYSTEM SINGLE PICKUP SYSTEM		PART NUMBER 709 814	
2				.XX	±.010				
3				FRACTIONAL		BRAWN BY	WTP	SCALE	NONE
4				MATERIAL		CHECKED BY		DATE	12-13-96
5						APPROVED BY			

709 814

TIMING SWITCH	
SWITCH POSITION	RETARD DISC DEGREES
0	7.5
1	7.0
2	6.5
3	6.0
4	5.5
5	5.0
6	4.5
7	4.0
8	3.5
9	3.0
10	2.5
11	2.0
12	1.5
13	1.0
14	0.5
15	0

NOTE: SWITCH ACTIVE WHEN 0V. APPLIED TO PIN "E" OF 5-PIN CONTROL CONNECTOR.

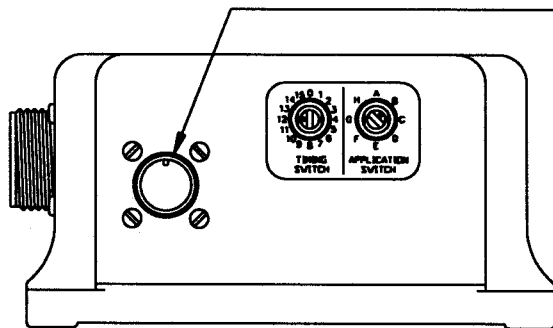
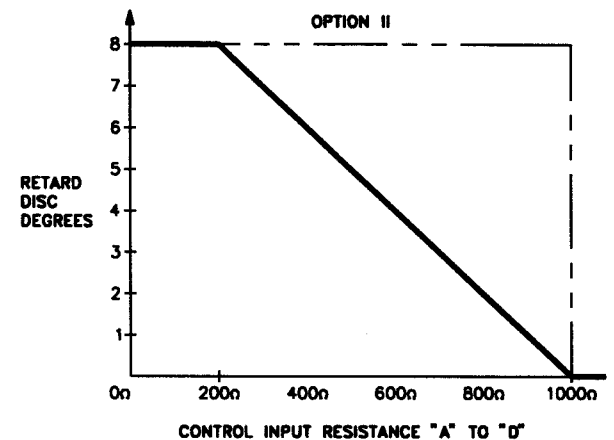
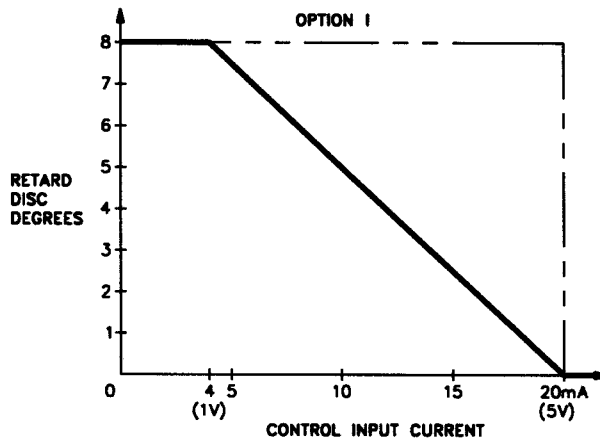

OPTION I - 4-20mA TIMING CONTROL  
5-PIN CONTROL CONNECTOR WIRING

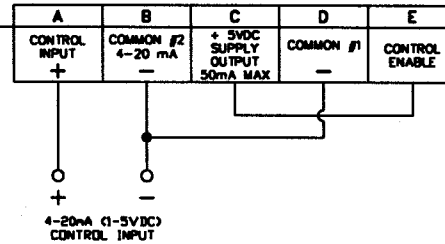

NOTE: B AND D MUST BE TIED TOGETHER TO (-) INPUT.

OPTION II - TWO FIXED TIMING SETTINGS  
5-PIN CONTROL CONNECTOR WIRING

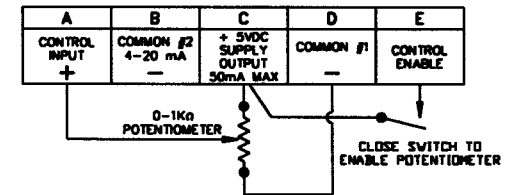

SET 1ST TIMING WITH TIMING SWITCH  
SET 2ND TIMING WITH POTENTIOMETER

REVISIONS				TOLERANCES (EXCEPT AS NOTED)	ALTRONIC INC.		
NO.	DATE	BY	DESCRIPTION	DECIMAL .XXX - ±.005 .XX - ±.010	TITLE TIMING CONTROL WIRING DISN 800 IGNITION SYSTEM		
1				FRACTIONAL	DRAWN BY	WTP	
2				MATERIAL	CHECKED BY	DATE	
3					APPROVED BY	SCALE	
4						NONE	
5						12-7-95	
						PART NUMBER	709 815

709 815



**SPECIFICATIONS:**

SUPPLY VOLTAGE: 5 TO 8 VOLTS D.C.  
 SUPPLY CURRENT: 50 mA. MAX.  
 OUTPUT VOLTAGE @ 5 ma.: 1.0 VOLT MAX.  
 OUTPUT CURRENT SINKING 10 mA. MAX.  
 STORAGE AND OPERATING TEMP.: -40°C TO +125°C  
 -40°F TO +357°F  
 ENCAPSULATED IN GLASS-FILLED EPOXY SUITABLE FOR ENGINE OIL OR OTHER NON-CONDUCTIVE MEDIA ONLY.  
 MAXIMUM OPERATING PRESSURE: 50 psi DIFFERENTIAL

**TYPICAL OUTPUT WAVEFORM**

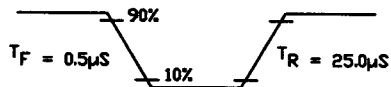

TRIGGERED BY THE NORTH POLE OF MAGNET 5 VOLT SUPPLY 1KΩ LOAD

**SCHEMATIC**

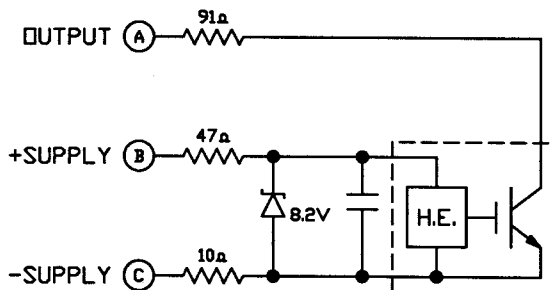

ALTRONIC P/N	T	L
791050-1	1.75"/44.5mm	3.30"/83.3mm
791050-2	2.50"/63.5mm	4.05"/102.8mm
791050-4	4.50"/114.3mm	6.05"/153.7mm
791050-6	6.00"/152.4mm	7.53"/191.8mm

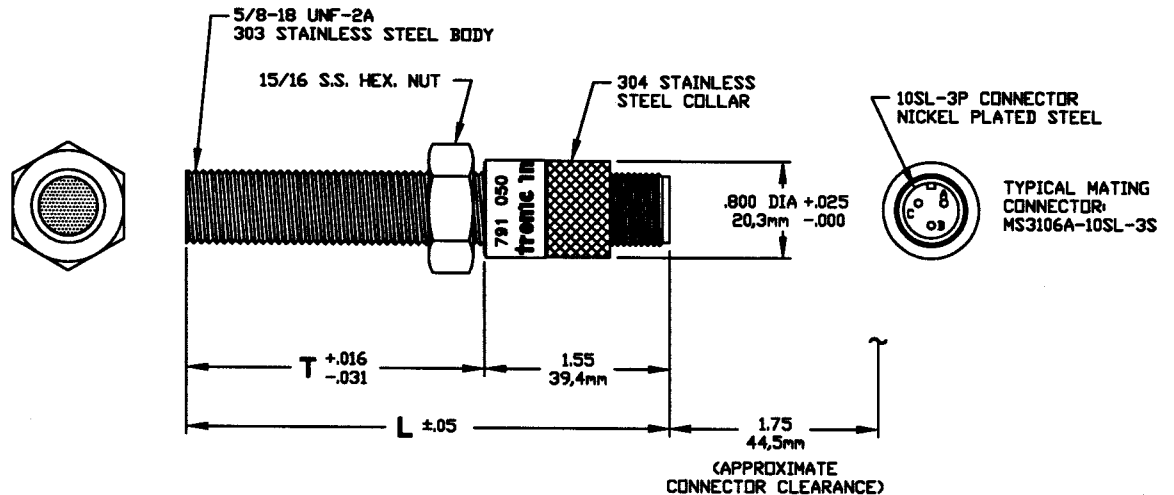

**NOTE:**

1. NORTH POLE OF MAGNET MUST FACE SENSING END WITH AIR GAP OF .030/.040 (.76/1.0).
2. CENTERLINE OF MAGNET'S ROTATION MUST RUN THROUGH CENTERLINE OF PICKUP.

**REVISIONS**

NO.	DATE	BY	DESCRIPTION
1	8-16-89	WTP	ADDED P/N 791 050-1, -4, REDRAWN ON CAD
2	4-9-90	DWA	ADD 791 050-6 TO CHART
3	11-6-96	WTP	ECN 960134
4	9-2-97	WTP	ECN 970105
5			

TOLERANCES (EXCEPT AS NOTED)
DECIMAL
FRACTIONAL
MATERIAL

ALTRONIC INC.

TITLE			
SALES DRAWING HALL EFFECT PICKUP			
DRAWN BY	DWA	SCALE	FULL
CHECKED BY		DATE	10-22-85
APPROVED BY			791 050

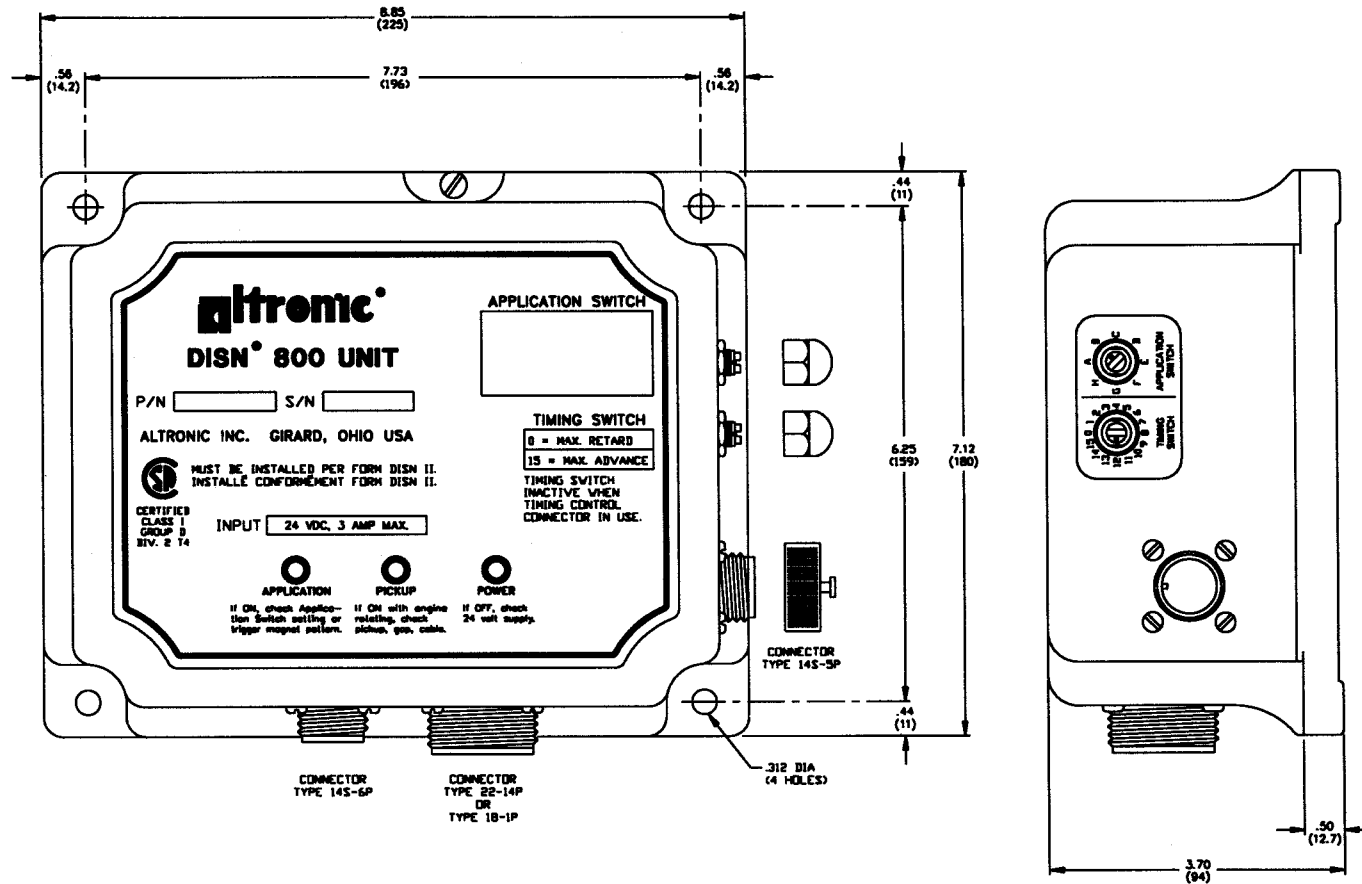

DIMENSIONS IN INCHES AND MILLIMETERS

REVISIONS				TOLERANCES UNLESS OTHERWISE SPECIFIED		ALTRONIC INC.			
NO.	DATE	BY	DESCRIPTION	FRACTIONAL	DECIMAL	TITLE			
1						DISN UNIT - 800 SERIES			
2						DESIGNED BY	WTP	SOLE FULL	PART NUMBER
3						DATE	11-29-95		799 044
4						APPROVED BY			
5									